

# MyT Virtue

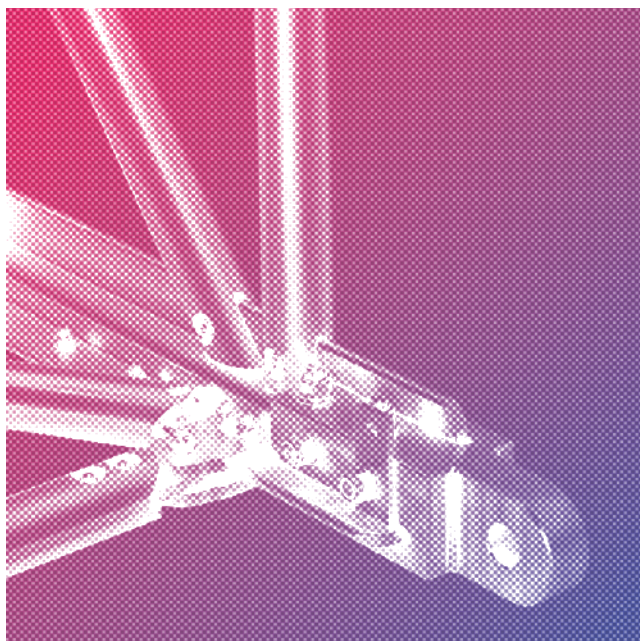

MyT Virtue is a new truss that's the smallest member of the MyT family. Made from EN AW-7003 T6 aluminium alloy, it features a folding design to save space during transportation and has a higher load capacity than our RL105A series and all other truss on the market with similar dimensions. It's the perfect choice for larger, more demanding indoor and outdoor events.

---

Chords A  
Extruded aluminium tube  $\varnothing$  60 mm  
EN AW-7003 T6

---

Diagonals B  
Extruded aluminium tube  $\varnothing$  60 mm  
EN AW-7003 T6

---

Ends C  
Aluminium forks connector  
EN AW-7003 T6

---

Connection system  
Steel  
11SMnPb37

---

Bolts  
cl. 10.9

---

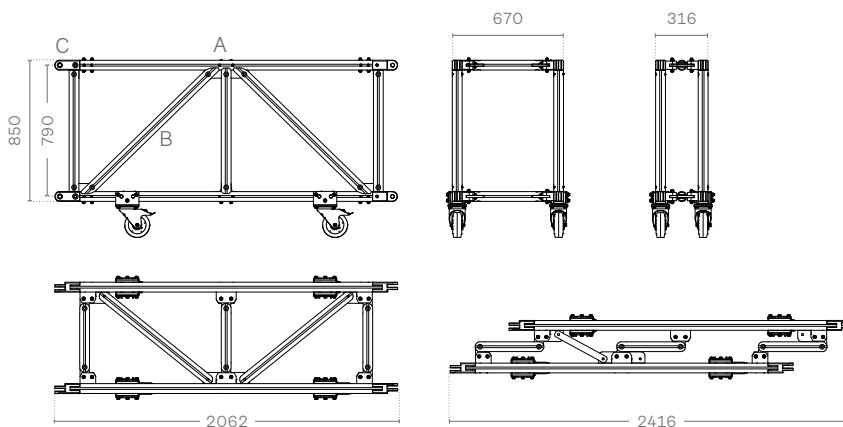

Section area  
5.284 mm<sup>2</sup>

---

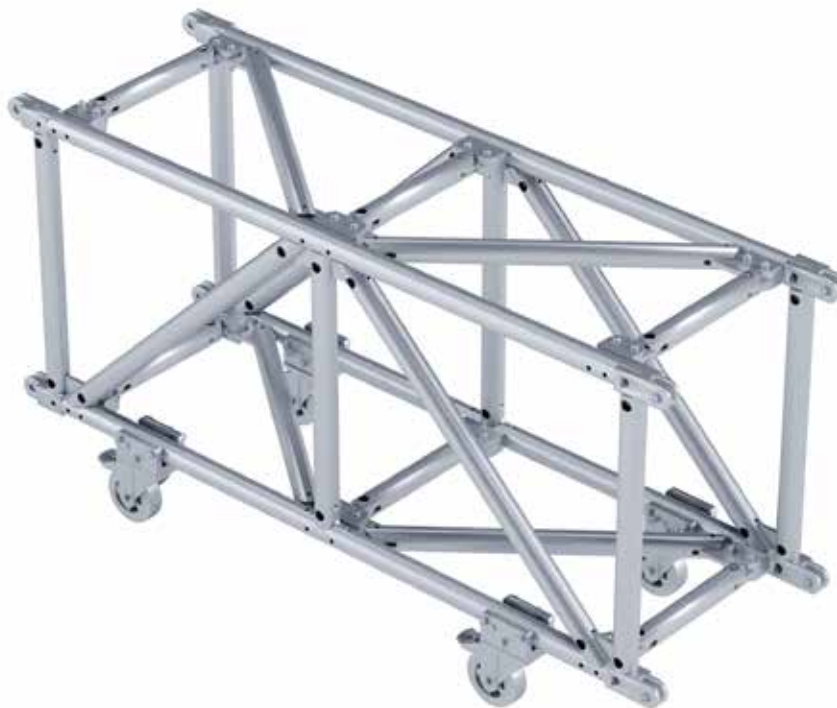

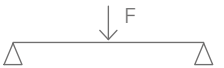
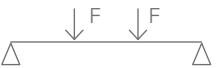

### Load table / Fork connection

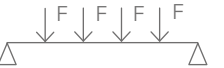
SPAN	Unif. distributed load			Centre point load			Third point load			Quarter point load			Fifth point load		
	Point load	Full load	Central deflection	Point load	Full load	Central deflection	Point load	Full load	Central deflection	Point load	Full load	Central deflection	Point load	Full load	Central deflection
m	kg/m	kg	mm	kg	kg	mm	kg	kg	mm	kg	kg	mm	kg	kg	mm
2	5047	10094	0.0	10094	10094	0.0	5047	10094	0.0	3365	10094	0.0	2524	10094	0.0
4	2492	9968	0.1	9381	9381	0.1	4984	9968	0.1	3323	9968	0.1	2492	9968	0.1
6	1640	9842	0.3	7980	7980	0.4	4628	9255	0.4	3281	9842	0.3	2460	9842	0.3
8	1214	9716	0.7	6916	6916	0.7	4117	8234	0.8	3043	9129	0.8	2429	9716	0.8
10	959	9590	1.3	6077	6077	1.3	3692	7384	1.3	2771	8313	1.4	2251	9003	1.5
12	789	9464	2.2	5394	5394	2.0	3332	6664	2.1	2534	7602	2.3	2079	8316	2.4
14	667	9338	3.5	4825	4825	3.0	3021	6043	3.2	2324	6973	3.4	1925	7698	3.5
16	576	9212	5.3	4341	4341	4.1	2749	5499	4.4	2137	6412	4.7	1785	7140	5.0
18	454	8168	6.9	3922	3922	5.5	2508	5016	5.9	1969	5906	6.4	1657	6629	6.8
20	356	7112	8.5	3554	3554	7.1	2292	4584	7.7	1778	5333	8.2	1482	5924	8.6
22	283	6224	10.4	3112	3112	8.7	2097	4194	9.7	1556	4668	9.9	1297	5187	10.4
24	228	5464	12.4	2732	2732	10.5	1919	3837	12.0	1366	4098	11.9	1138	4554	12.4
26	185	4802	14.6	2401	2401	12.5	1755	3509	14.5	1200	3601	14.0	1000	4001	14.7
28	151	4216	17.0	2108	2108	14.7	1581	3162	17.2	1054	3161	16.4	878	3513	17.1
30	123	3691	19.6	1846	1846	17.1	1384	2768	19.9	923	2768	19.0	769	3076	19.7

Load table has been prepared in accordance with UNI ENV 1999-1-1 (Eurocode 9). When calculating the allowable loads it is assumed that the load is suspended from the bottom chord and the truss is supported from the top chord at each end. The values shown in the table are the allowable static loads that

can be applied to the truss. This is the live load or the payload. The self weight of the truss has been taken into account when calculating the values in the table. It should be noted that this are idealised loading conditions and the User shall re-analyze the truss for the loading conditions which prevail for the application being considered.