

Date of issue:
2011

MyT TRUSS SYSTEM TECHNICAL DATA

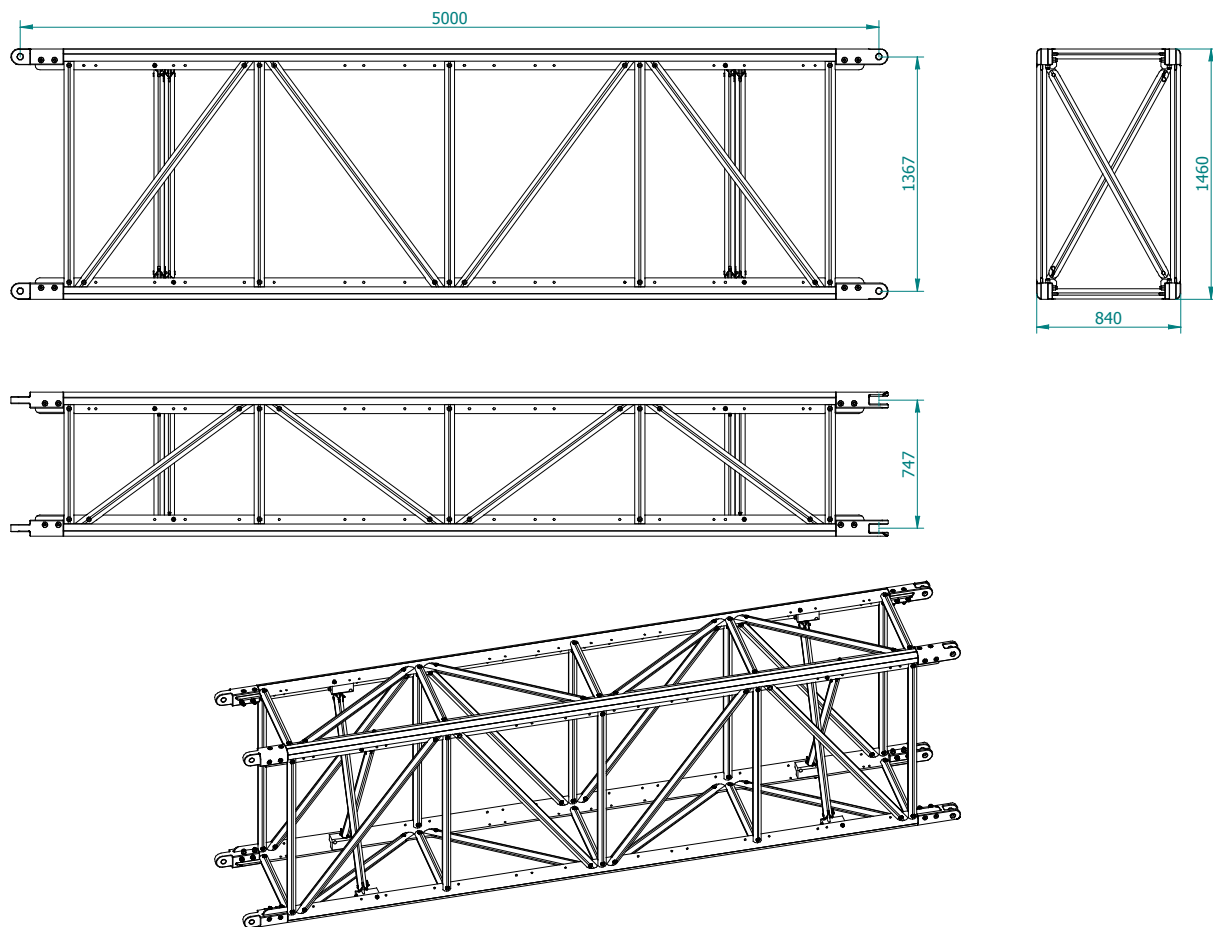

Description	Specification
External dimensions (height x width)	840 mm x 1460 mm
Distance between axis	747 mm x 1367 mm
Lengthways tubes	Extruded aluminium EN AW-7003 T6
Crossways tubes	Extruded aluminium EN AW-7003 T6
Connection system	Fork system (aluminium EN AW-7003 T6) and steel pin (11SMnPb37)
Bolts	cl. 10.9
Available length [cm]	250 – 500
Self-weight (approx.)	86 kg/m

CARICO UNIFORME. DISTRIBUITO UNIFORMLY DISTRIBUTED LOAD		
span	q_{am}	$q_{am} \cdot L$
[m]	[kg/m]	[kg]
10	1290	12900
20	610	12200
35	310	10850

Load table has been prepared in accordance with UNI ENV 1999-1-1 (Eurocode 9). It is assumed that the trusses are simply supported at the end connection and that static loads will be applied to the node points. The application of the load shall be on the centre line of the truss. The values shown in the table are the allowable static loads that can be applied to the truss. This is the live load or the payload. The self-weight of the truss has been taken into account when calculating the values in the table. It should be noted that this are idealised loading condition and the User shall re-analyse the truss for the loading condition which prevail for the application begin considered.